

UNCONTROLLED COPY IF PRINTED

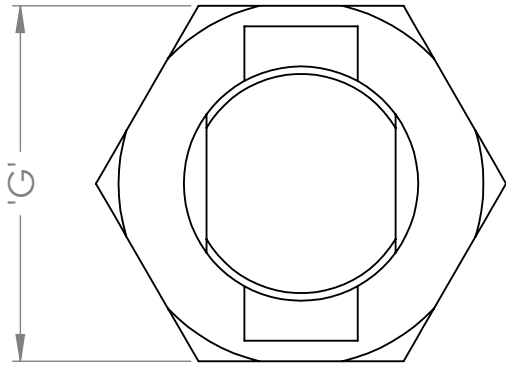

CLAMP			MAX COND. SIZE (mm ²)	DIMENSIONS in 'mm' ('B' is in 'inches')							
CLAMP TYPE	BRASS - NATURAL	BRASS - ELECTRO TINNED		A	B	C	D	E	F	G	H
A	B22	B22T	16	5.3	½"	10.4	30.2	7.9	11.1	17.9	6.3
B	B24	B24T	35	8.3	5/8"	13.2	36.5	9.5	14.3	23.2	6.3
C	B25	B25T	70	10.9	7/8"	17.9	44.5	9.5	22.2	27.7	7.1
D	B26	B26T	95	12.9	7/8"	17.9	50.8	9.5	22.2	27.7	7.1
E	B28	B28T	185	18.5	1¼"	23.2	66.7	9.5	25.4	42.1	7.9

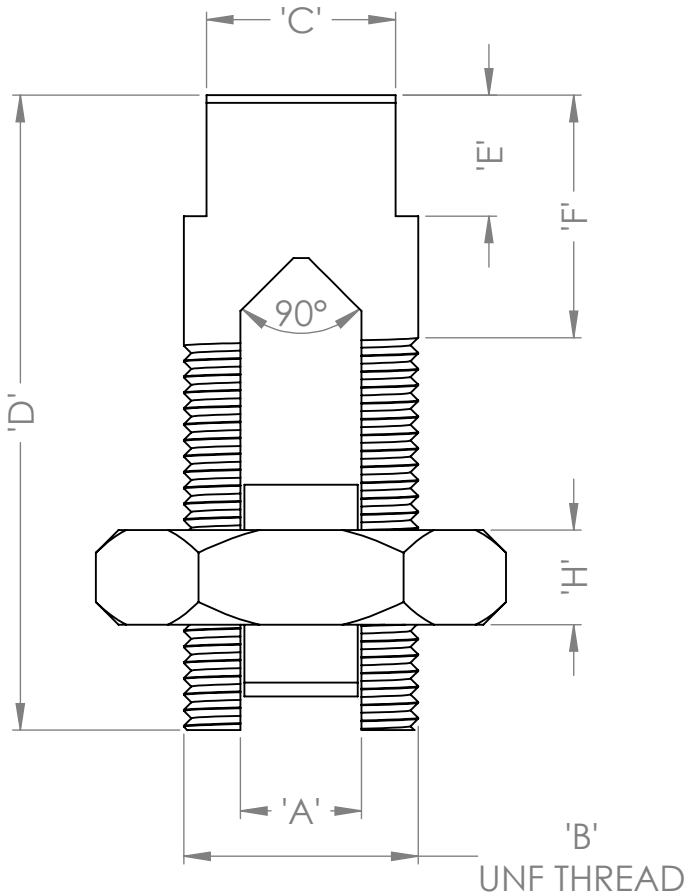

PROPRIETARY AND CONFIDENTIAL
 THE INFORMATION CONTAINED IN THIS DRAWING IS THE SOLE PROPERTY OF FULTON INDUSTRIES AUSTRALIA PTY. LTD. ANY REPRODUCTION IN PART OR AS A WHOLE WITHOUT THE WRITTEN PERMISSION OF FULTON INDUSTRIES AUSTRALIA PTY. LTD. IS STRICTLY PROHIBITED.

DIMENSIONAL TOLERANCES:
 (except where otherwise stated)
 Up to 6mm ±0.1mm
 Over 6 up to 30mm ±0.2mm
 Over 30 up to 120mm ±0.3mm
 Over 120 up to 315mm ±0.5mm
 Over 315 up to 500mm ±1.0mm
 Over 500mm ±5.0mm
 All Angles (degrees) ±1°

DO NOT SCALE DRAWING

	NAME	DATE
DRAWN BY:	ST	20/01/14
CHECKED BY:	MD	01/04/14

THIRD ANGLE PROJECTION

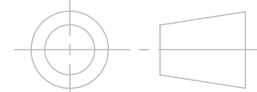

MATERIAL:

COMMENTS:

1. ALL MEASUREMENTS ARE IN MILLIMETRES.
2. REMOVE ALL SHARP EDGES AND BURRS.

FULTON INDUSTRIES AUSTRALIA PTY LTD
TEL: 61 2 4323 4242 FAX: 61 2 4322 6197
EMAIL: sales@fultonindustries.com.au

**TITLE: ROUND HEAD SPLIT BOLTS
 GENERIC DWG**

SIZE	DWG. NO.	REVISION
A4	8-S0219	-

SCALE: 2:1

SHEET 1 OF 1