

ALL DIMENSIONS IN MILLIMETRES - DO NOT SCALE - PLEASE ASK IF IN DOUBT

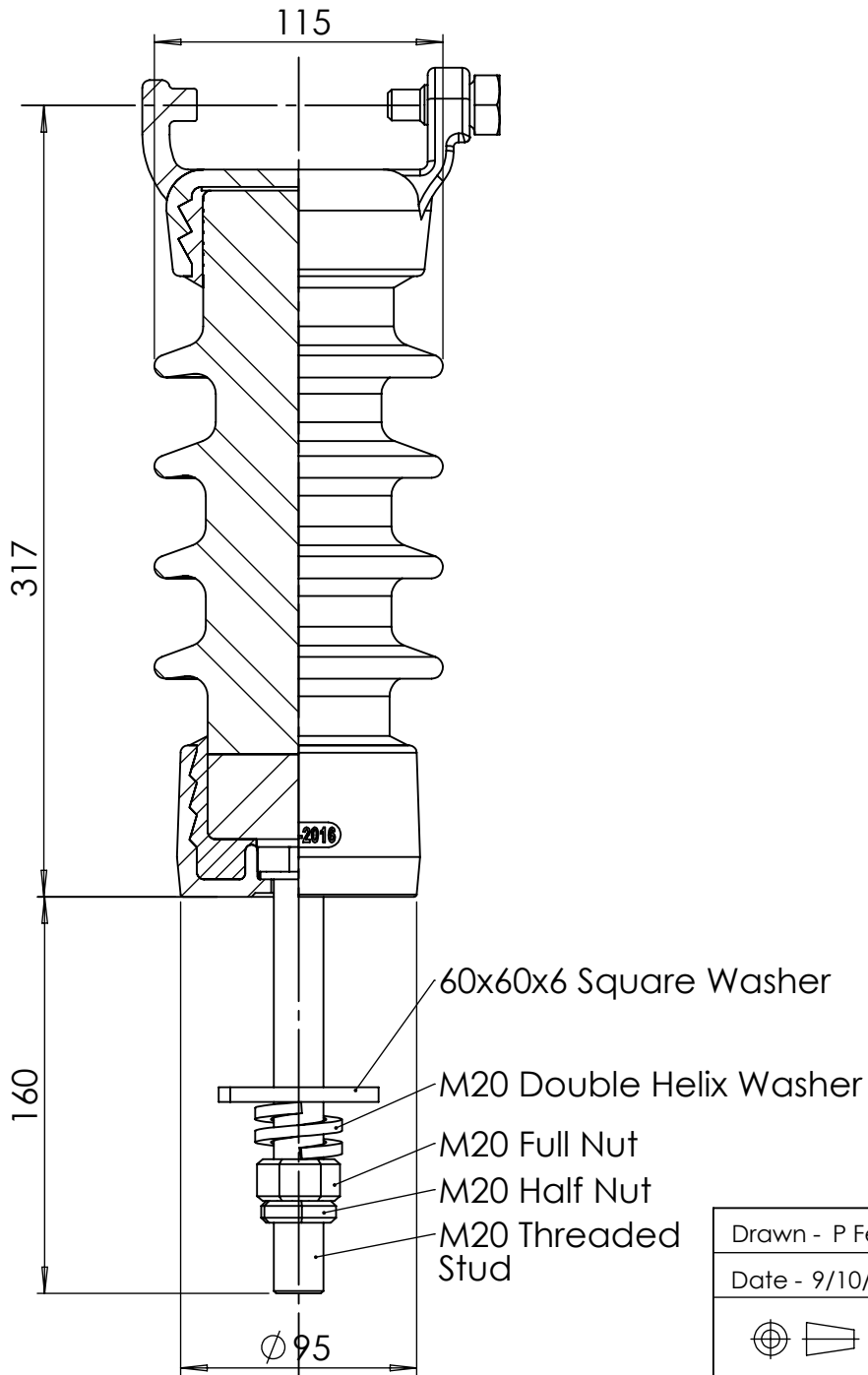

Technical Specifications

SYSTEM HIGHEST VOLTAGE 11 kV

WITHSTAND TEST VOLTAGES

- | | | |
|----|--------------------------------------|--------|
| a. | Power frequency - wet (Vertical) | 55 kV |
| b. | Power frequency - wet (Horizontal) | 70 kV |
| c. | Power frequency - dry | 90 kV |
| d. | Lightning impulse - dry (Calculated) | 105 kV |

FLASHOVER TEST VOLTAGES

- | | | |
|----|------------------------------------|--------|
| a. | Power frequency - wet (Vertical) | 55 kV |
| b. | Power frequency - wet (Horizontal) | 75 kV |
| c. | Power frequency - dry | 100 kV |

MINIMUM FAILING LOADS

- | | | |
|----|----------------------|--------|
| a. | Cantilever (Upright) | 9.5 kN |
| b. | Tension | 25 kN |

CREEPAGE DISTANCES

- | | | |
|----|-----------|--------|
| a. | Total | 310 mm |
| b. | Protected | 60 mm |
| c. | Flashover | 190 mm |

Gross weight 7 kg

Issue	Mod. No.	Date
H	6814	6/10/23
G	3650	24/5/15
F	3467	6/12/12
E	3446	3/10/12
D	3424	14/5/12
C	3416	10/4/12

Drawn - P Ferris
Date - 9/10/2023

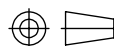

NEW ZEALAND INSULATORS



TEPUKA

NEW ZEALAND INSULATORS LTD
Tel: +64-3-687 8100
Fax: +64-3-615 8125
e-mail: sales@nzinsulators.co.nz

11 kV CLAMP TOP LINE POST
C/W M20 x 160 FIXED STUD

D724-0526/H