

ALL DIMENSIONS IN MILLIMETRES - DO NOT SCALE - IF IN DOUBT PLEASE ASK

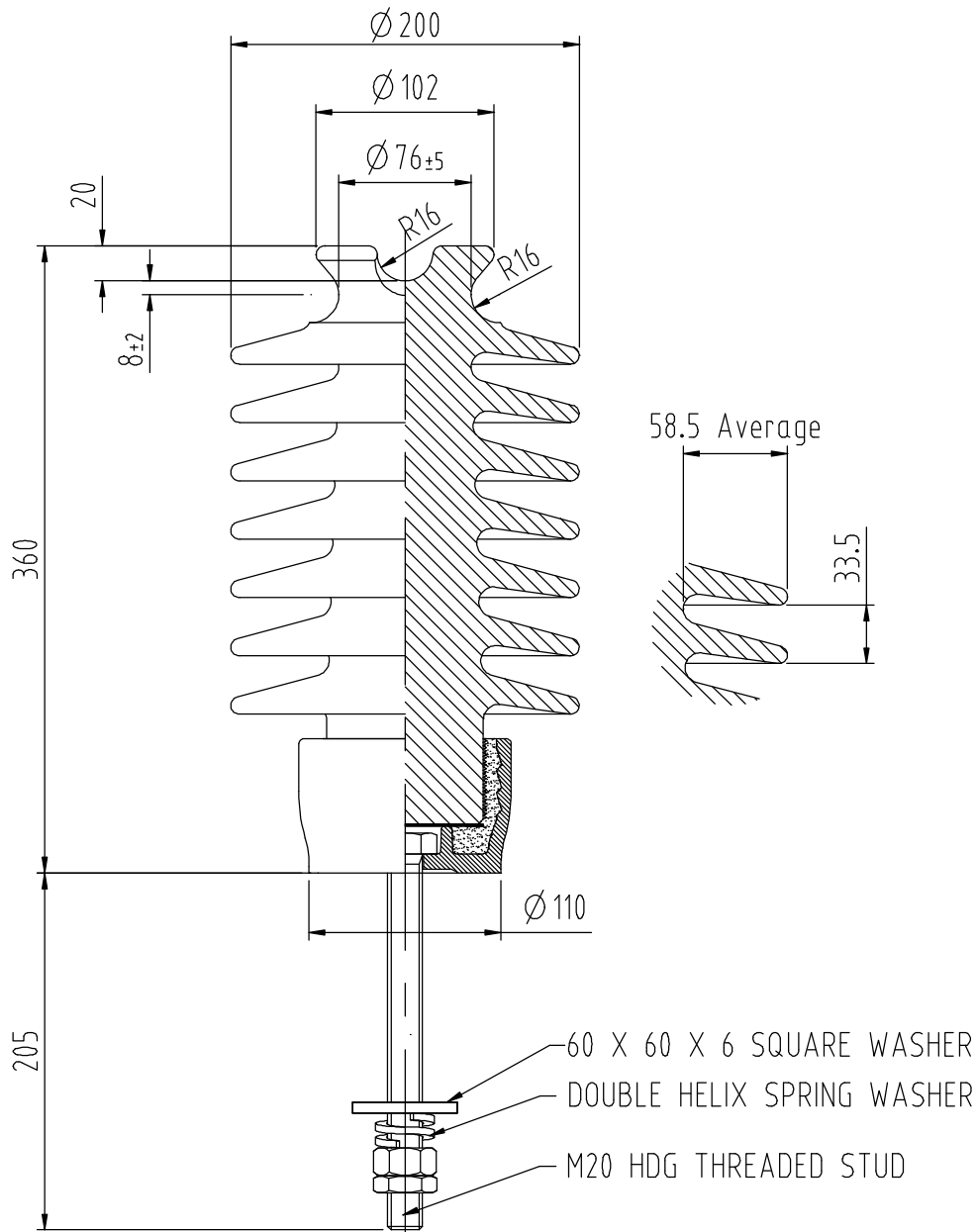

Technical Specification

	DESIGNED VALUES
<u>SYSTEM HIGHEST VOLTAGE</u>	36 kV
<u>WITHSTAND TEST VOLTAGES</u>	
a. Power frequency – wet (Vertical)	84 kV
b. Power frequency – wet (Horizontal)	99 kV
c. Power frequency – dry	112 kV
d. Lightning Impulse – dry (Calculated)	200 kV
<u>FLASHOVER TEST VOLTAGES</u>	
a. Power frequency – wet (Vertical)	89 kV
b. Power frequency – wet (Horizontal)	113 kV
c. Power frequency – dry	122 kV
<u>MINIMUM FAILING LOADS</u>	
a. Cantilever (Upright)	13.5 kN
<u>CREEPAGE DISTANCES</u>	
a. Total	915 mm
b. Protected	385 mm
c. Flashover	285 mm
Gross weight	12.5 kg
Pollution Performance N° (ESAA Publication D (b) 19-1975)	= --

Issue Mod. No.	Date
H 3483	11.1.13
G 3354	19.10.12
E 3339	18.8.11
D 3333	3.7.11
C 3325	23.5.11

Drawn J. Bain
Date 15.11.2010

NEW ZEALAND INSULATORS **nzi** TEMUKA

NEW ZEALAND INSULATORS LTD
Tel: +64-3-687 8100
Fax: +64-3-615 8125
e-mail: sales@nzinsulators.co.nz



36kV TIE TOP LINE POST
FIXED LENGTH STUD TYPE

D632-0570/H