

ALL DIMENSIONS IN MILLIMETRES - DO NOT SCALE - IF IN DOUBT ASK

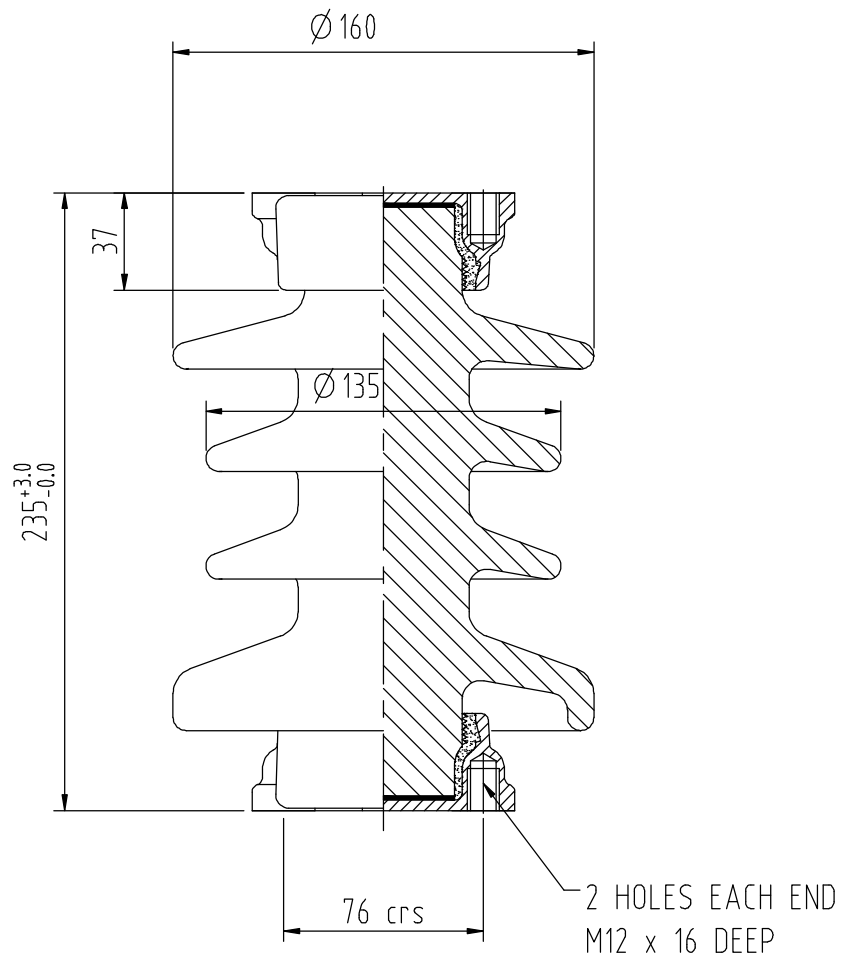

Technical Specification

	DESIGNED VALUES
<u>SYSTEM HIGHEST VOLTAGE</u>	12 kV
<u>WITHSTAND TEST VOLTAGES</u>	
a. Power frequency - wet	67 kV
<u>MINIMUM FAILING LOADS</u>	
a. Cantilever	4.0 kN
b. Torsion	300 Nm
c. Tension	25 kN
<u>CREEPAGE DISTANCES</u>	
a. Total	445 mm
b. Protected	165 mm
c. Flashover	225 mm

Pollution Performance N\* ( ESAA Publication D (b) 19-1975 ) =

E	3115	2.7.04
Issue	Mod. No.	Date

Drawn J. Bain  
Date 4.6.2004



FIRST ANGLE PROJECTION



**NZ Insulators Ltd.**

New Zealand Insulators Ltd.  
Tel: +64-3-615 0085  
Fax: +64-3-615 8125  
e-mail: sales@nzinsulators.co.nz

12kV SWITCH INSULATOR  
'T' INSERT REPLACEMENT

D412-0529/E