

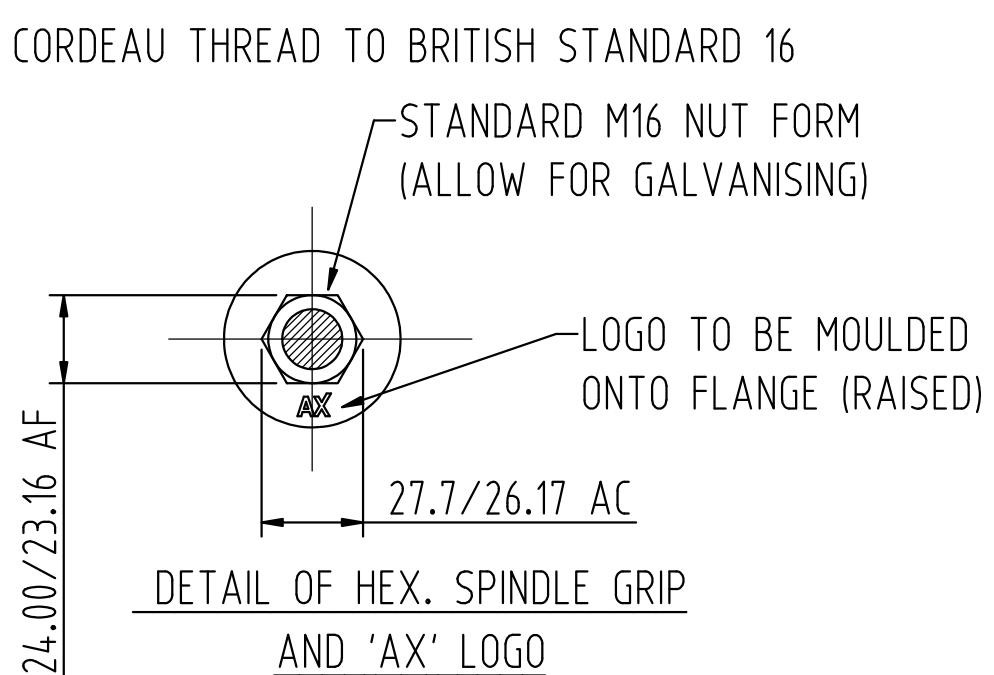

ALL DIMENSIONS IN MILLIMETRES – DO NOT SCALE – IF IN DOUBT ASK

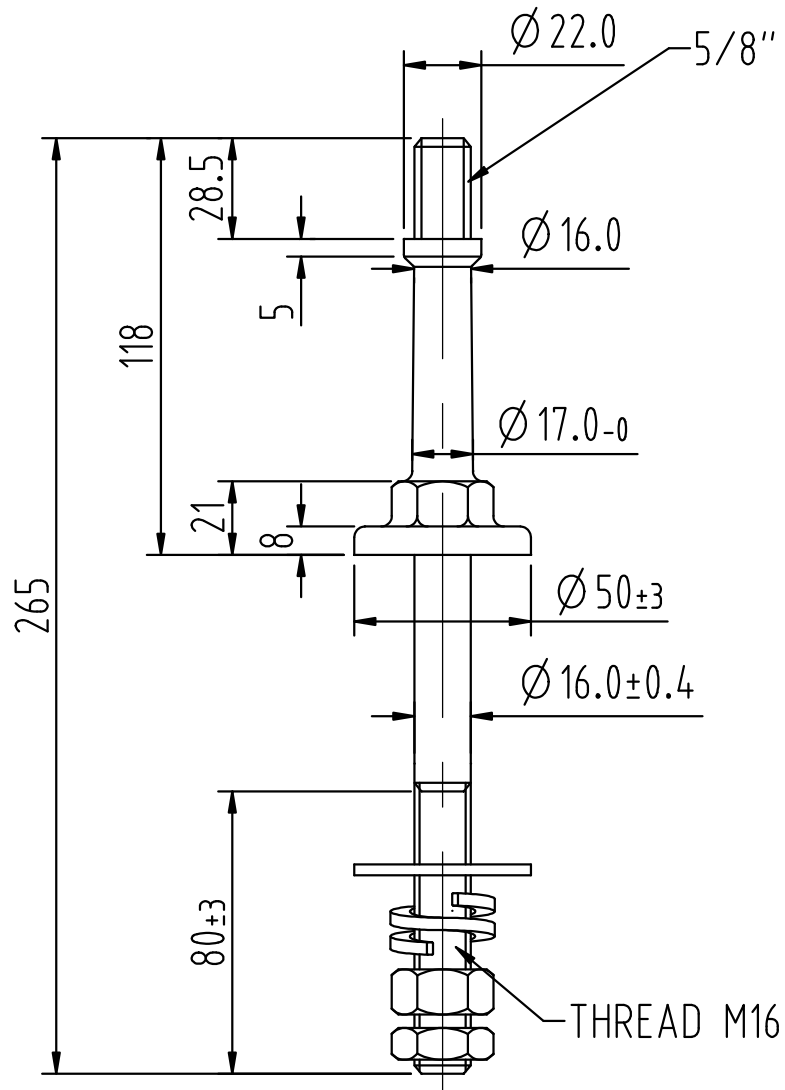
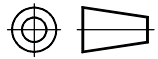

NOTE
 Each spindle supplied with:-
 One M16 HDG Hex. full nut
 one M16 HDG Hex. thin nut
 One 50x50x3 HDG square flat washer
 One M16 HDG double coil spring washer

				Drawn J. Bain	 NEW ZEALAND INSULATORS TEMUKA	New Zealand Insulators Ltd. Tel: +64-3-615 0085 Fax: +64-3-615 8125 e-mail: sales@nzinsulators.co.nz
				Date 2.5.2011		
Material AISI 1025 STEEL				 FIRST ANGLE PROJECTION	M16 INSULATOR SPINDLE 118/147 - 5/8" CORDEAU THREAD	
Finish HOT DIP GALVANISED TO ASTM A-153						
Tolerance - unless otherwise noted ± 1						
Issue	Mod.N°	Date	Casting Drg.N°	EDP N° 541427	D374-2131/A	