

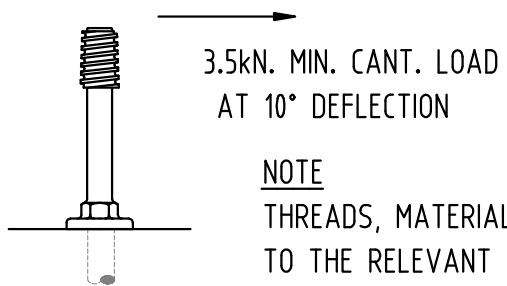

ALL DIMENSIONS IN MILLIMETRES - DO NOT SCALE - IF IN DOUBT ASK

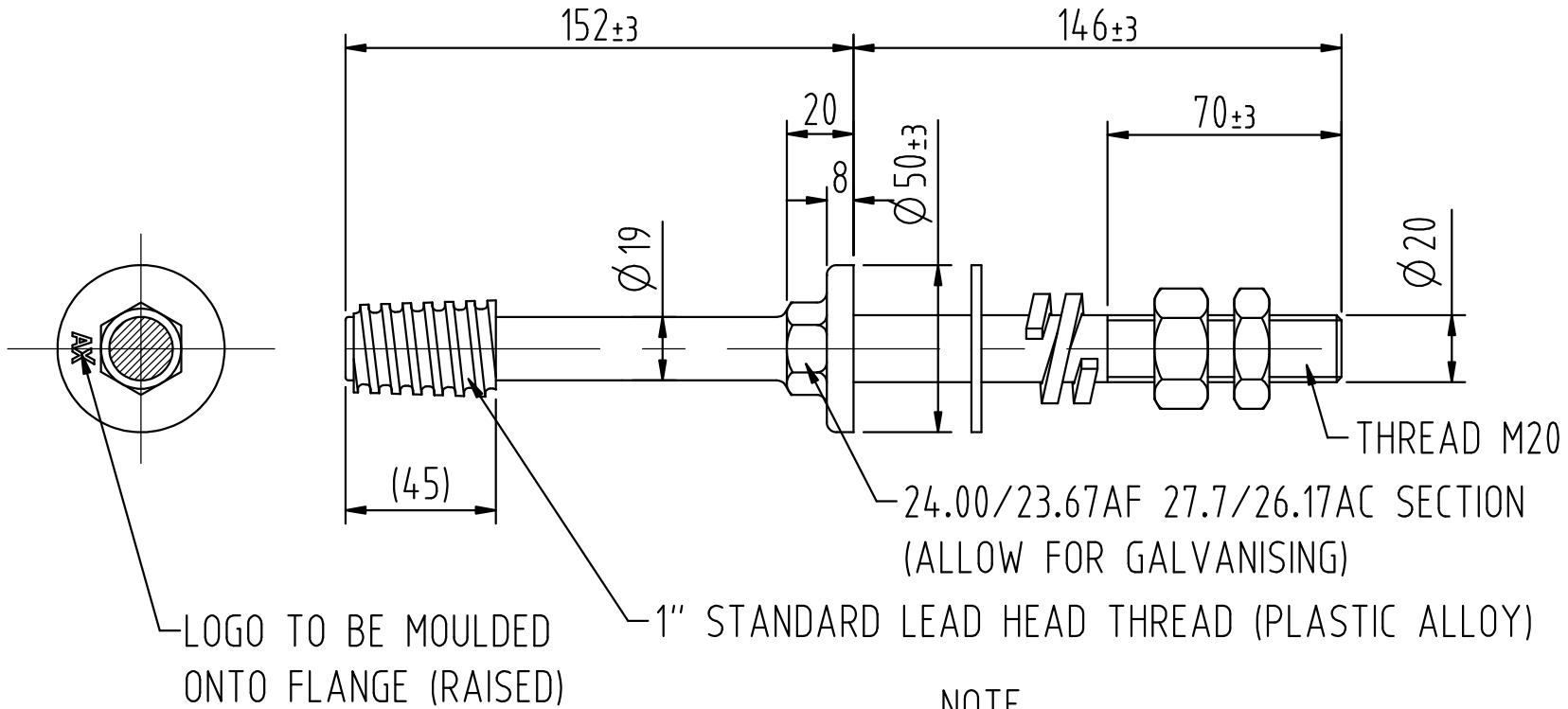

NOTE
THREADS, MATERIALS AND FINISH ALL TO THE RELEVANT NEMA STANDARDS.

NOTE
Each spindle supplied with:-
One M20 HDG Hex. full nut
One M20 HDG Hex. thin nut
One 50x50x3 HDG square flat washer
One M20 HDG double coil spring washer

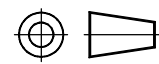
				Drawn J. Bain	 NEW ZEALAND INSULATORS TEMUKA	New Zealand Insulators Ltd. Tel: +64-3-615 0085 Fax: +64-3-615 8125 e-mail: sales@nzinsulators.co.nz
				Date 3.5.2011		
Material AISI 1025 STEEL				 FIRST ANGLE PROJECTION	1" PLASTIC ALLOY HEAD 152/146 INSULATOR SPINDLE	
Finish HOT DIP GALVANISED TO ASTM A-153						
Tolerance - unless otherwise noted ± 1						
Issue	Mod.N°	Date	Casting Drg.N°	EDP N° 541451	D374-2134/A	